

Applicare frenafiletti medio al montaggio
Apply thread-locking medium during assembly

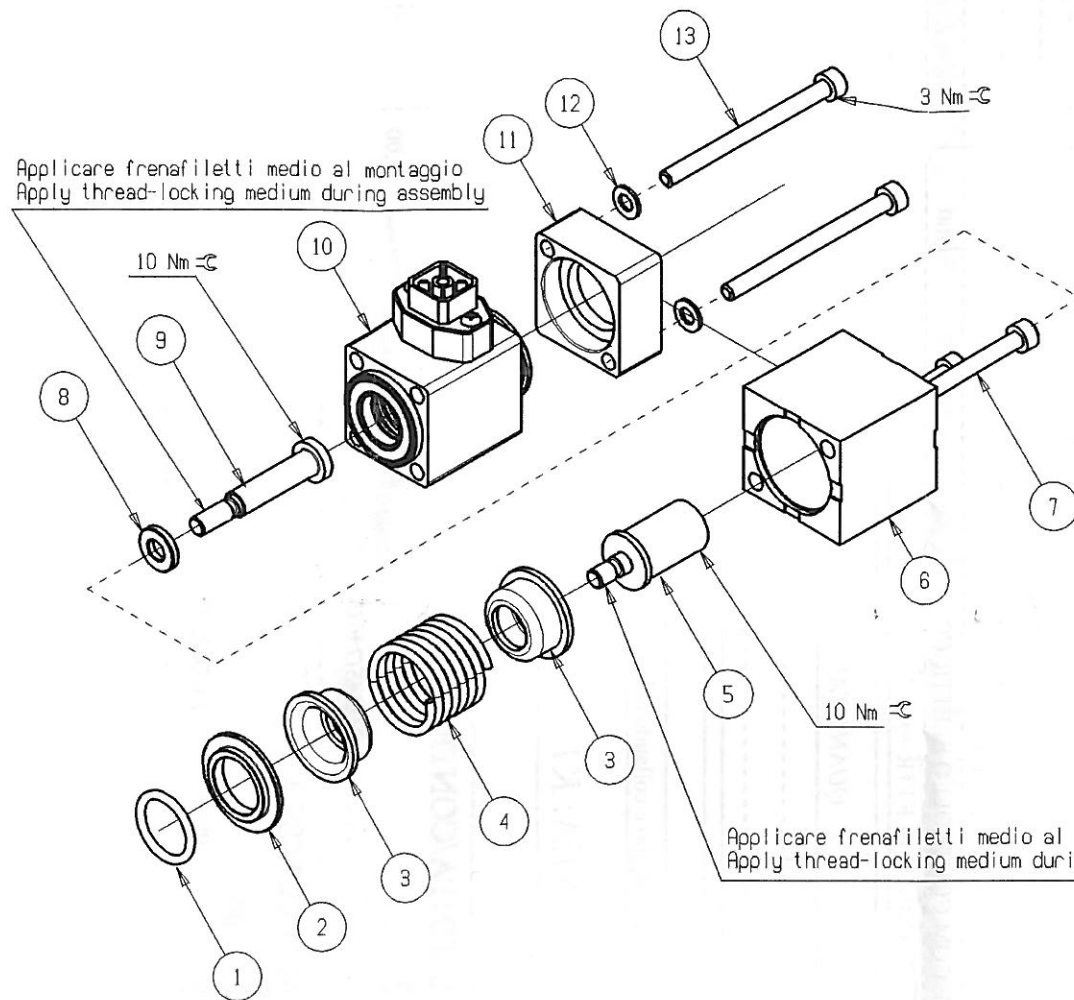

Applicare frenafiletti medio al montaggio
Apply thread-locking medium during assembly

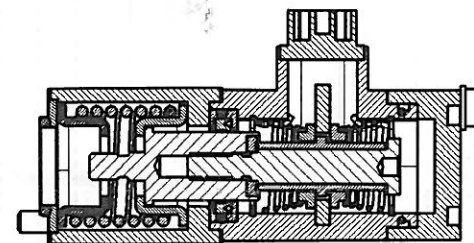
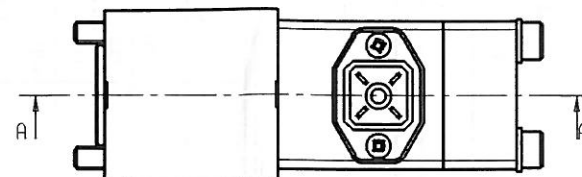

SECTION A-A

13	411020549	VITE TC CE P80 UNI 5931 5x65 ZINC.	M	2
12	411090501	ROD. PIANA ZINC UNI 6502 D.5	M	2
11	423404134	FLANGIA	M	1
10	450002008	DIO ASS. CONTR. ELETTR. + GUARN.	M	1
9	423411102	VITE CON. CONTROLLO ELETTRICO	M	1
8	422814004	RONDELLA	M	1
7	411020532	VITE TC CE P80 UNI 5931 5x40 ZINC.	M	2
6	422728015	CILIND.	M	1
5	423408027	GIUNTO	M	1
4	421801020	NOLLA P.S.	M	1
3	421801046	DISTANZIALE APPOGGIO NOLLA	M	2
2	420118007	ANEL. CENTR.	M	1
1	412010805	O.R. 70SH 17.65 X 2.02 (5-256)	M	1
Pae	Codice	Descrizione	UM	Q.tà

ASSEMBLY: D4 + F0360-F0370 CONTR. ELETTR.

hydro control
Bologna Italy

Group		Scale	
D4		1:1	
Approv.	Date	Prototipo	
MA	28/08/2012	196019805	
Designer	Date	CODE	Proc.
VP	20/05/2012	320004027	3